

## 555 Debouncer

### Parts

555 Timer    10 k $\Omega$  (1)    330  $\Omega$  (1)    0.1  $\mu$ F (1)    LED  
22 k $\Omega$  (1)    10  $\mu$ F

### Description and Operation

It is often necessary to produce a single pulse in an application. Using just a pushbutton will not provide a clean single pulse. Due to an effect called 'bounce' several pulses of various pulse widths will be generated. For example, if a switch is connected to an up counter and the switch is pressed, it will usually count up by more than one.

Josh Hintze suggested using the 555 timer in the monostable mode or 'one-shot'. A 555 timer is configured as drawn below to provide a single pulse when the pushbutton is pressed. The pulse duration is calculated from the equation  $1.1 \times R \times C$ .

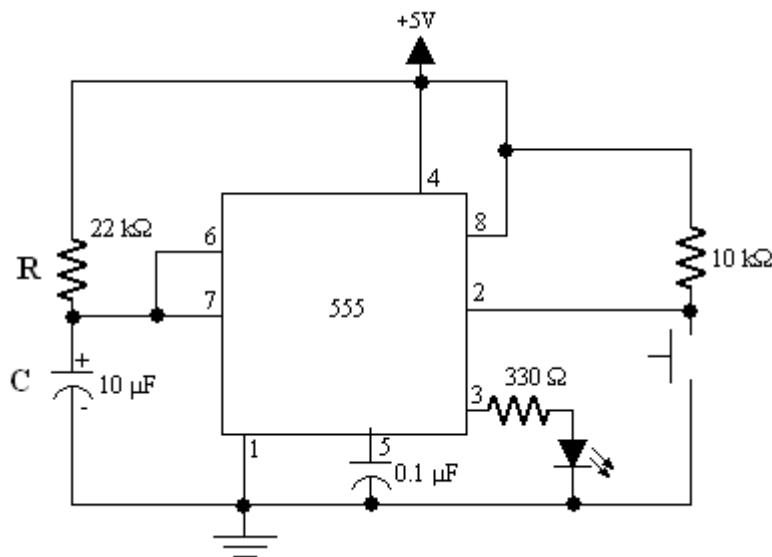

**Photo**

